

DASH NO.	GLASS
-KK	KK1
-S	KSF5
-SS	KSF10
-K	KF2
-C	KC331
-Q	QUARTZ

PART NUMBER		
-EXAMPLE-		
A A994 - 271 - KK		
REV	DRAWING NO.	LENGTH MATERIAL
		NO SOAK

NO.	NOTES
1	0.010X45° CHAMFER ALL SHARP EDGES.
2	POLISHED INSIDE AND OUT TO CLARITY 80 - 50 SCRATCH DIG.
3	END FINE GROUND. BLANK CUT LENGTH = L + 0.5".
4	STRENGTHEN - 3 DAY SOAK.
5	L = ROD LENGTH - 0.440.

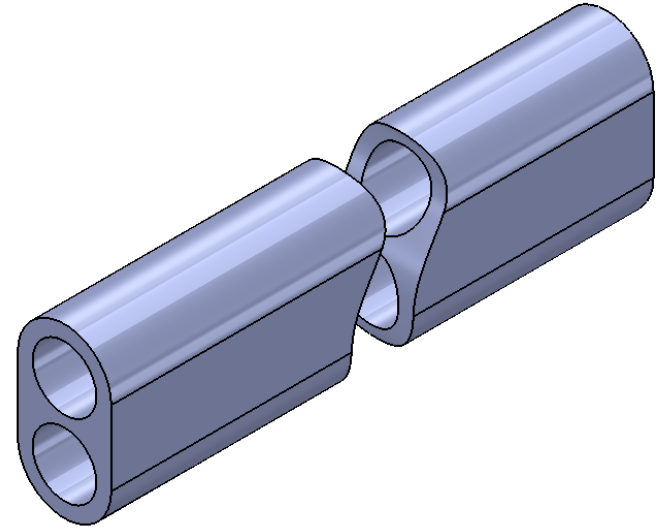

$$L = \text{_____} \begin{matrix} +0.004 \\ -0.000 \end{matrix}$$

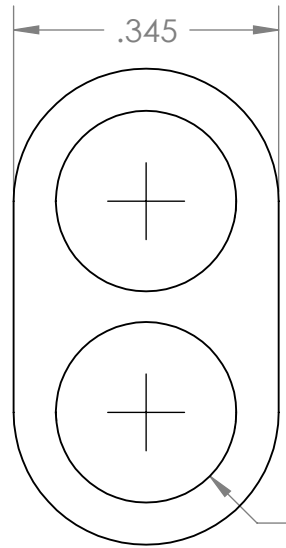

SCALE 4:1

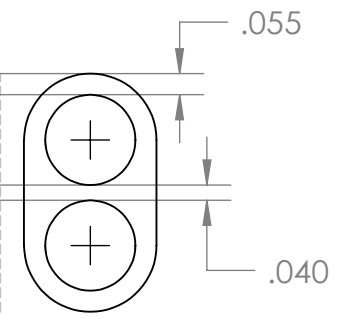
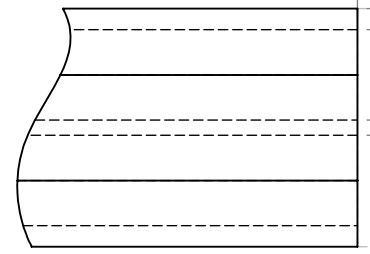
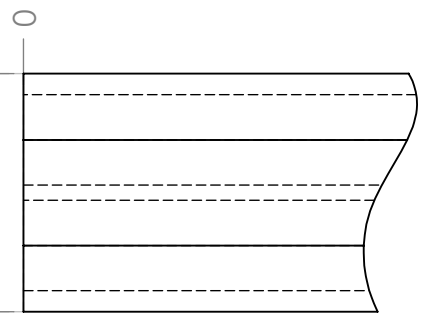
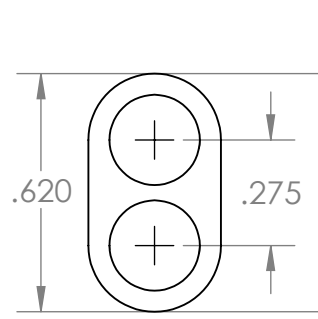

REV	DATE	DESCRIPTION	BY	APPR
A	16JUN92	NOTCH & 1.640 LENGTH REMOVED.	GR	GR
B	07JUL94	NOTE NUMBER 4 ADDED.	GR	GR
C	05JAN10	HOLE TOLERANCE CHANGED.	CXY	CRH

UNLESS OTHERWISE SPECIFIED:
 DIMENSIONS ARE IN INCHES
 (EXCEPT WHERE NOTED)
 TOLERANCES:
 ONE PLACE DECIMAL ±0.020
 TWO PLACE DECIMAL ±0.010
 THREE PLACE DECIMAL ±0.005

	NAME	DATE
DRAWN	CXY	05JAN10
CHECKED	CRH	05JAN10
ENG APPR.		
MFG APPR.		
Q.A.		

KIGRE, INC.

TITLE:
TUBE, FILTER - 275/2

PROPRIETARY AND CONFIDENTIAL
 THE INFORMATION CONTAINED IN THIS DRAWING IS THE SOLE
 PROPERTY OF KIGRE, INC. ANY REPRODUCTION IN PART OR AS
 A WHOLE WITHOUT THE WRITTEN PERMISSION OF KIGRE, INC. IS
 PROHIBITED.

NEXT ASSY	USED ON
APPLICATION	

MATERIAL
SEE CHART

FINISH
SEE NOTES

DO NOT SCALE DRAWING

SIZE	DWG. NO.	REV
A	A994-_____-____	C
SCALE: 2:1	WEIGHT:	SHEET 1 OF 1