

DASH NO.	GLASS	PART NUMBER
-KK	KK1	-EXAMPLE-
-S	KSF5	B A2513 - 332 - KK
-SS	KSF10	
-K	KF2	REV DRAWING NO. LENGTH MATERIAL
-C	KC331	
-Q	QUARTZ	NO SOAK, LIGHT FIRE POLISH ON ENDS.

NO.	NOTES
1	BLANK CUT LENGTH = L + 0.5".
2	L = LASER ROD LENGTH - 0.680" (USE 3.0" FOR 80 mm).
3	POLISHED INSIDE AND OUT TO CLARITY, TO 80 - 50 SCRATCH - DIG.
4	ENDS - FINE GROUND & CHAMFER ON O.D. & I.D. 0.005" - 0.010".
5	STRENGTHEN - 3 DAY SOAK. (EXCEPT WHERE NOTED).

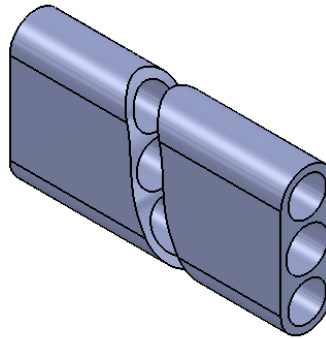

$$L = \text{_____} \begin{matrix} +0.004 \\ -0.000 \end{matrix}$$

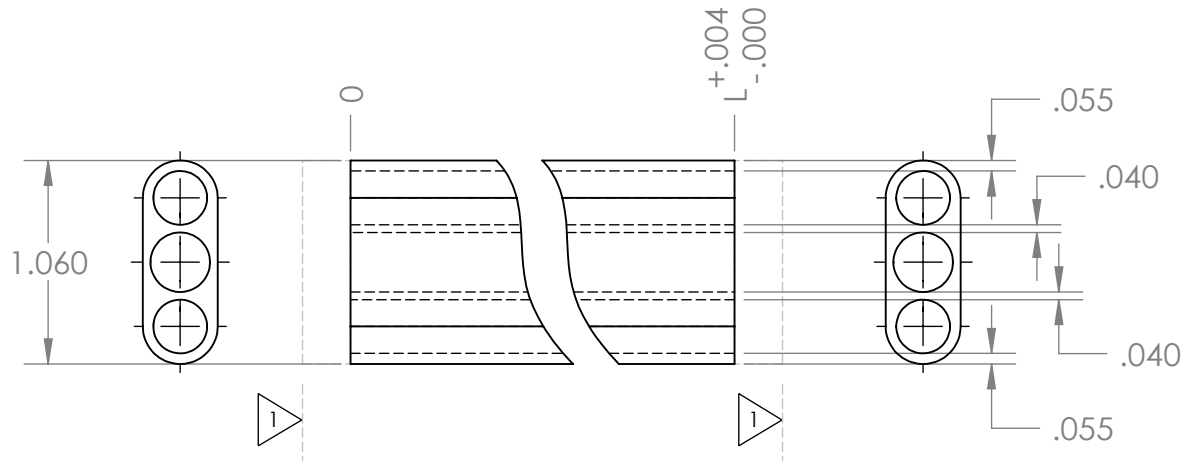
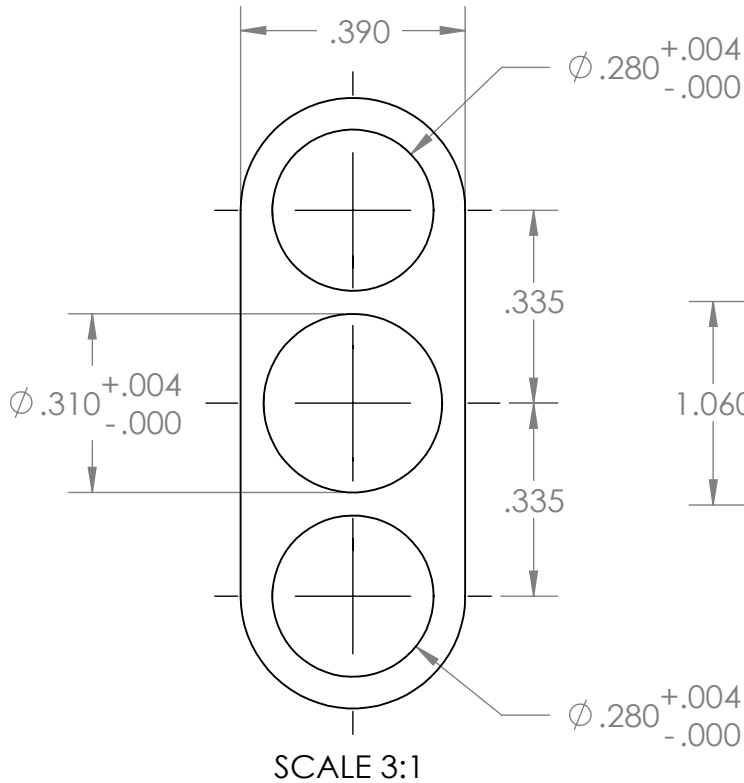

REV	DATE	DESCRIPTION	BY	APPR
A	07JUL94	NOTE 1 ADDED.	GR	GR
B	12JAN10	HOLE TOLERANCE CHANGED.	CXY	CRH

UNLESS OTHERWISE SPECIFIED:		NAME	DATE
DIMENSIONS ARE IN INCHES (EXCEPT WHERE NOTED)		DRAWN	CXY 12JAN10
TOLERANCES:		CHECKED	CRH 12JAN10
ONE PLACE DECIMAL ±0.020		ENG APPR.	
TWO PLACE DECIMAL ±0.010		MFG APPR.	
THREE PLACE DECIMAL ±0.005		Q.A.	
INTERPRET GEOMETRIC TOLERANCING PER:		COMMENTS:	
MATERIAL		SEE CHART	
FINISH		SEE NOTES	
DO NOT SCALE DRAWING			

KIGRE, INC.

TITLE:
TUBE, FILTER - 335/3

SIZE DWG. NO. REV
A A1531-_____-____ B

SCALE: 1:1 WEIGHT: SHEET 1 OF 1

PROPRIETARY AND CONFIDENTIAL
THE INFORMATION CONTAINED IN THIS DRAWING IS THE SOLE PROPERTY OF KIGRE, INC. ANY REPRODUCTION IN PART OR AS A WHOLE WITHOUT THE WRITTEN PERMISSION OF KIGRE, INC. IS PROHIBITED.

NEXT ASSY

USED ON

APPLICATION