

DASH NO.	GLASS	PART NUMBER
-KK	KK1	-EXAMPLE-
-S	KSF5	B A2513 - 332 - KK
-SS	KSF10	
-K	KF2	REV DRAWING NO. LENGTH MATERIAL
-C	KC331	
-Q	QUARTZ	NO SOAK, LIGHT FIRE POLISH ON ENDS

NO.	NOTES
1	POLISH INSIDE AND OUT TO CLARITY, TO 80 - 50 SCRATCH - DIG.
2	SEE PUMP CHAMBER ASSEMBLY FOR LENGTH (L).
3	ENDS-FINE GROUND & CHAMFER ON O.D. & I.D. (SAW CUT IS OK).
4	STRENGTHEN - 3 DAY SOAK. (EXCEPT WHERE NOTED).
▷	BLANK CUT LENGTH = L + 0.5".

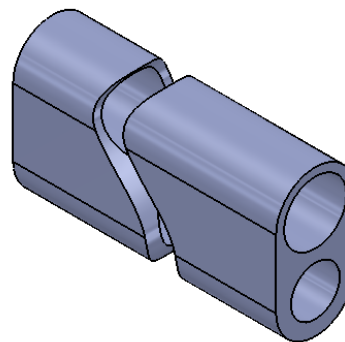

$$L = \text{_____} \begin{matrix} +0.004 \\ -0.000 \end{matrix}$$

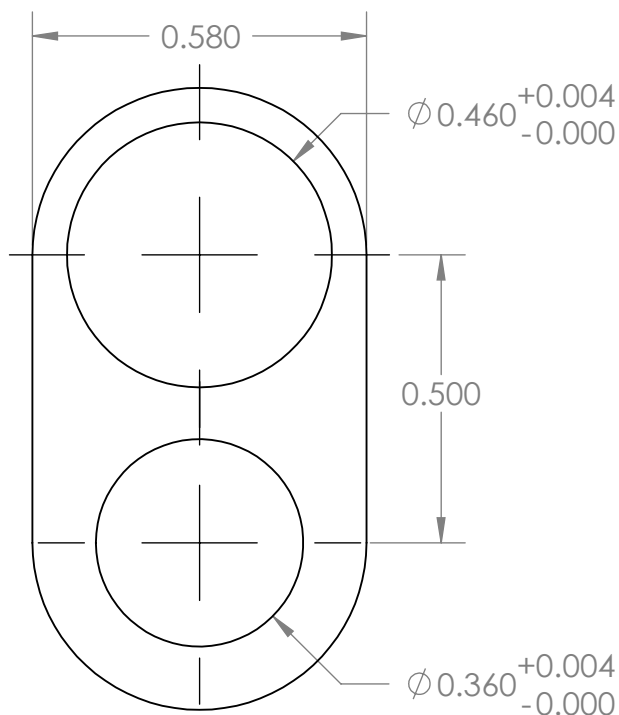

SCALE 3:1

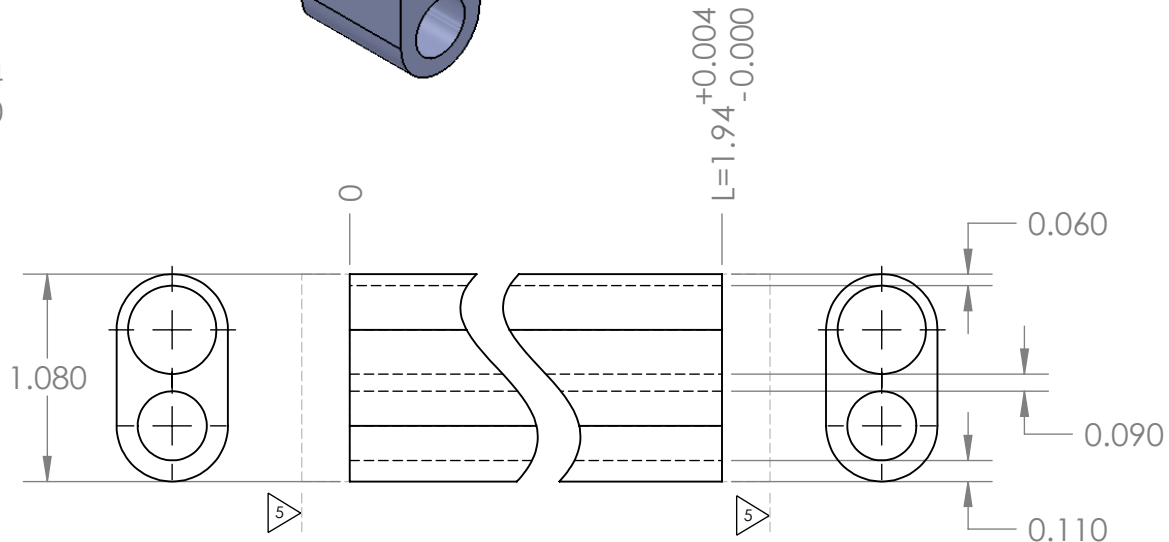

UNLESS OTHERWISE SPECIFIED:

DIMENSIONS ARE IN INCHES
(EXCEPT WHERE NOTED)
TOLERANCES:
ONE PLACE DECIMAL ±0.020
TWO PLACE DECIMAL ±0.010
THREE PLACE DECIMAL ±0.005

INTERPRET GEOMETRIC
TOLERANCING PER:

MATERIAL

SEE CHART

FINISH

SEE NOTES

DO NOT SCALE DRAWING

NAME DATE

DRAWN	CXY	22JAN10
CHECKED	CRH	22JAN10
ENG APPR.		
MFG APPR.		

Q.A.

COMMENTS:

KIGRE, INC.

TITLE:

TUBE, FILTER - 500/2

SIZE	DWG. NO.	REV
A	A1484-____-____	0

SCALE: 1:1	WEIGHT:	SHEET 1 OF 1
------------	---------	--------------

REV	DATE	DESCRIPTION	BY	APPR
		PROPRIETARY AND CONFIDENTIAL THE INFORMATION CONTAINED IN THIS DRAWING IS THE SOLE PROPERTY OF KIGRE, INC.. ANY REPRODUCTION IN PART OR AS A WHOLE WITHOUT THE WRITTEN PERMISSION OF KIGRE, INC. IS PROHIBITED.	NEXT ASSY	USED ON
		APPLICATION		

5

4

3

2

1